

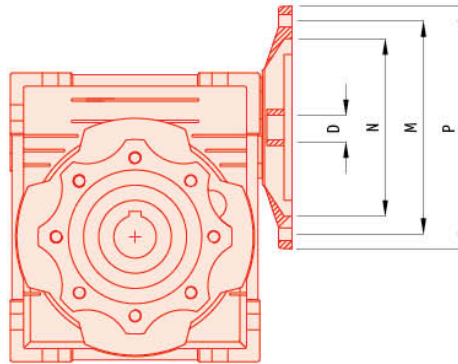

MSF MOTOREDUCTORES DE VIS SIN FIN MSF SERIES WORM GEARED MOTORS

PREDISPOSICIÓN DE ACOPLAMIENTO A MOTOR / MOTOR COUPLING



TIPO TYPE	PAM IEC	N	M	P	D											
					7.5	10	15	20	25	30	40	50	60	80	100	
MSF 025	56 B14	50	65	80	9	9	9	9	-	9	9	9	9	-	-	
MSF 030	63 B5	95	115	140	11	11	11	11	11	11	11	-	-	-	-	
	63 B14	60	75	90	-	-	-	-	-	-	-	-	-	-	-	
	56 B5	80	100	120	9	9	9	9	9	9	9	9	9	9	-	
MSF 040	56 B14	50	65	80	-	-	-	-	-	-	-	-	9	9	9	
	71 B5	110	130	160	14	14	14	14	14	14	14	-	-	-	-	
	71 B14	70	85	105	-	-	-	-	-	-	-	-	-	-	-	
MSF 050	63 B5	95	115	140	11	11	11	11	11	11	11	11	11	11	11	
	63 B14	60	75	90	-	-	-	-	-	-	-	-	9	9	9	
	56 B5	80	100	120	-	-	-	-	-	-	-	-	9	9	9	
MSF 063	80 B5	130	165	200	19	19	19	19	19	19	-	-	-	-	-	
	80 B14	80	100	120	-	-	-	-	-	-	-	-	-	-	-	
	71 B5	110	130	160	14	14	14	14	14	14	14	14	14	14	-	
MSF 075	63 B5	95	115	140	-	-	-	-	-	-	11	11	11	11	11	
	90 B5	130	165	200	24	24	24	24	24	24	-	-	-	-	-	
	90 B14	95	115	140	-	-	-	-	-	-	-	-	-	-	-	
MSF 090	80 B5	130	165	200	-	-	-	19	19	19	19	19	19	19	19	
	80 B14	80	100	120	-	-	-	-	-	-	-	14	14	14	14	
	71 B5	110	130	160	-	-	-	-	-	-	-	14	14	14	14	
MSF 110	100/112 B5	180	215	250	28	28	28	-	-	-	-	-	-	-	-	
	100/112 B14	110	130	160	-	-	-	-	-	-	-	-	-	-	-	
	90 B5	130	165	200	24	24	24	24	24	24	24	-	-	-	-	
MSF 130	90 B14	95	115	140	-	-	-	-	-	-	19	19	19	19	19	
	80 B5	130	165	200	-	-	-	-	-	-	19	19	19	19	19	
	80 B14	80	100	120	-	-	-	-	-	-	19	19	19	19	19	
MSF 150	132 B5	230	265	300	38	38	38	38	-	-	-	-	-	-	-	
	100/112 B5	180	215	250	28	28	28	28	28	28	28	28	28	28	-	
	90 B5	130	165	200	-	-	-	-	24	24	24	24	24	24	24	
MSF 170	80 B5	130	165	200	-	-	-	-	-	-	-	-	-	-	19	
	80 B14	80	100	120	-	-	-	-	-	-	-	-	-	-	19	
	132 B5	230	265	300	38	38	38	38	38	38	38	-	-	-	-	
MSF 200	100/112 B5	180	215	250	-	-	-	-	28	28	28	28	28	28	28	
	90 B5	130	165	200	-	-	-	-	-	-	-	-	-	-	24	
	90 B14	95	115	140	-	-	-	-	-	-	-	-	-	-	24	